

PRODUCT BRIEF

Intel Atom® C3000 Processor



Efficient Intelligence at the Edge



Delivering low power, efficient intelligence, to the farthest edge of the network

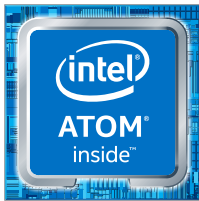

As communication service providers, enterprise IT, and cloud service providers seek to speed new service delivery and handle exponential growth in the number of users accessing their services, it is essential that they optimize infrastructure for density and cost, both in the data center and at the network edge. Inefficient data center scaling drives up space and cost and increases environmental impact, while fixed function, proprietary devices at the network edge hinder the ability of IT and service providers to rapidly deploy and manage new services.

The Intel Atom® C3000 processor delivers new options for cost and infrastructure optimization, by bringing the efficient performance and intelligence of Intel Atom processor into a dense, lower-power system-on-a-chip, designed specifically for network and edge solutions. The Intel Atom C3000 processor is Intel's third generation system-on-a-chip (SoC) based CPU manufactured on Intel's optimized 14nm process technology. It can be deployed for a variety of light scale-out workloads that require very low power, high density and high I/O integration including network routers, switches, storage, security appliances, dynamic web serving, and more.

Storage



Up to **4.0X**
storage
performance
improvement¹

Network

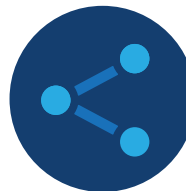

Up to **3.4X**
network
performance
improvement²

Compute



Up to **2.3X**
compute
performance
improvement³

Available in a range of configurations from 2 core to 16 core and up to 256GB¹ DDR4 2400 MHz ECC (SODIMM, UDIMM, or RDIMM) of addressable memory, this system-on-a-chip (SoC) has an integrated platform controller hub (PCH), integrated I/O, up to four integrated 10 Gigabit Intel® Ethernet adapters, and a thermal design point (TDP) of 8.5 watts to 32 watts. It can run the same software and instruction sets as Intel® Xeon® processors to provide software consistency and deployability from the data center to the network edge.

It also provides advanced server-class capabilities, including:

- Integrated Intel® QuickAssist Technology (Intel® QAT) offering up to 20 Gbps cryptography and up to 20 Gbps of compression, to free up valuable cycles on processors to perform value-added, differentiating functionality
- Integrated Intel® Ethernet supporting up to four 10 GbE adapters delivering value-added data transmission throughput and network performance
- Built-in hardware virtualization with Intel® Virtualization Technology (Intel® VT) to enable dynamic provisioning of services as communication service providers extend network functions virtualization (NFV) to the network edge
- Up to 20 lanes of flexible high-speed input/output (HSIO), supporting a combination of PCIe* gen 3, SATA3, USB 3.0 and fixed eMMC.
- Intel x86 64-bit Software Support for scalable performance and broad application/workload compatibility
- Reliability, Availability, and Serviceability (RAS) features, including support for error-correcting code (ECC) memory and platform-level error management and resilience
- Support for industrial Internet of Things (IoT) usages and Extended Ambient Operation Temperature (eTEMP*) from -40°C to +85°C

Network Transformation

To realize the potential of 5G, Communications Service Providers need to quickly and easily deploy new services to the network edge, decreasing the amount of traffic going back to the mobile core and the data center, further reducing network latency. The new 5G radio interface will receive a performance boost and edge networks are going to be more intelligent and change the way services are delivered to mobile subscribers.

The Intel Atom C3000 processor supports this transformation, and Intel is working with communications equipment vendors to increase computing, bandwidth, and storage capacity at the edge—including 5G base stations with integrated server capabilities, virtualized customer premise equipment (vCPE), software-defined wide area network (SD-WAN), and network appliances.

Learn more at [intel.com/networktransformation](https://www.intel.com/networktransformation)

Storage

Data accumulation is a very real issue for many enterprises. The ongoing growth and generation of important data brings unique requirements of data protection and integrity outside of performance demands of enterprise servers. Fortunately the surface area at the enterprise edge is uniquely positioned to deploy effective data reduction and data security through storage fundamentals such as deduplication and encryption which is ideal for cold and longer term storage needs. The Intel Atom C3000 processor delivers storage primitives functions in a highly integrated affordable package that can be deployed at the edge where the primary requirements are affordability, low power, and small footprint.

Learn more at [intel.com/storage](https://www.intel.com/storage)

Internet of Things (IoT)

The Intel Atom C3000 processor extends low-power Intel® Architecture into new segments and accelerates IoT innovation across a wide range of environments and use cases. With industry-leading performance per watt, low TDP, and unprecedented levels of configurable high-speed I/O, this new SoC family delivers next-generation, multicore performance and scalability for low-power, high-density, and fanless designs. Plus, integrated technologies and pre-validated solutions enable industrial, energy, aerospace, robotics, public sector, and other customers with demanding edge IoT workloads to easily extract value from data, reduce time to market, and innovate new connected technologies faster.

Learn more at [intel.com/iot](https://www.intel.com/iot)

Scalable Solutions

Intel works with companies worldwide to understand and appreciate their business needs, service demands, challenges and opportunities with technology. The insights and knowledge gained from these partnerships help us design the most advanced solutions to help you be successful. The Intel Atom C3000 processor delivers on customer demands for low power and efficient performance that are required in select network products and solutions. Intel's portfolio of solutions extended from the Intel Atom C3000 processor to the new Intel® Xeon® Scalable processors. The Intel Xeon Scalable platform provides the foundation for a powerful data center platform that creates an evolutionary leap in agility and scalability.

Learn more at [intel.com/xeonscalable](https://www.intel.com/xeonscalable)

Typical Intel Atom® C3000 Platform Configuration

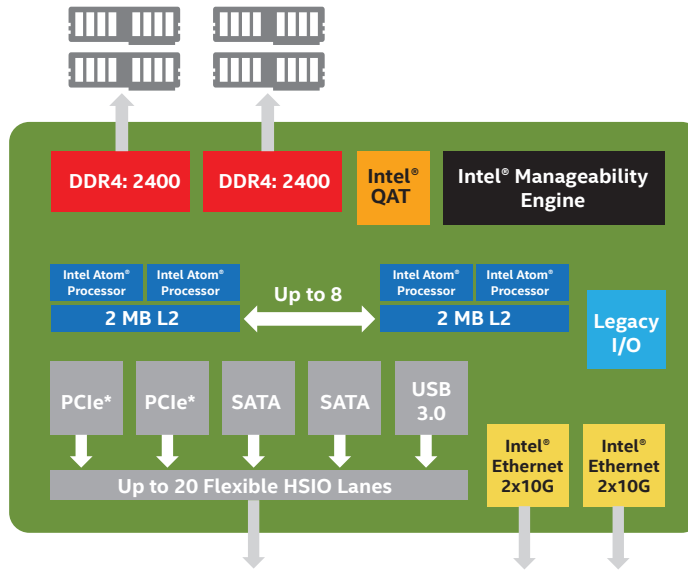

Overview

Features	Benefits
Low Power Advantage	
Intel Atom® C3000 Processor	Dense, lower-power system-on-a-chip, designed specifically for network and edge solutions. <ul style="list-style-type: none"> Manufactured on Intel's optimized 14nm process technology Optimized for light scale-out workloads that require very low power, high density, and high I/O integration
Design Flexibility	
Thermal Design Power (TDP)	8.5 watts to 32 watts for low power product design flexibility
Core Count	Up to 16 cores, delivering efficient intelligence to edge workloads
Cache Size	Less than 8 cores, L2 is 2 MB/Core and more than 8 cores, L2 is 2MB/Core Pair. Fast memory, close to the processor cores, supporting overall performance and workload processing.
Memory Support	Up to 2 channels of DDR4 ECC supporting data integrity and system reliability
Maximum Memory Capacity	Up to 256GB ¹ supporting workload loading, processing and data transmission
PCI Express* 3.0 ports	Extra capacity and flexibility for storage and networking connections <ul style="list-style-type: none"> Up to double⁴ the I/O bandwidth of prior-generation PCIe*
Serial ATA 3.0 (SATA 3.0)	Faster data access, system startups, and application load times <ul style="list-style-type: none"> Doubles⁵ data throughput versus previous generation for faster hard drive performance
Reliability	
Support for error-correcting (ECC) memory	Better data integrity and system reliability through automatic data correction
Intel® Server Platform Services (Intel® SPS)	Designed for managing rack-mount servers, Intel Server Platform Services provides a suite of tools to control and monitor power, thermal, and resource utilization
Security and Efficient Performance	
Intel® QuickAssist Technology (Intel® QAT)	Hardware acceleration for compute-intensive workloads, such as cryptography and data compression, by offloading the functions to a specialized logic engine, freeing the processor to focus on other workload operations.
Integrated Intel® Ethernet	Cost and performance savings with integrated Intel® Ethernet enabling extensive compatibility, broad product selection, performance and acceleration, easy installation and reliability, worldwide availability, and world-class support
Intel® Virtualization Technology (Intel® VT) for IA-32 and Intel 64 (Intel® VT-x)	Faster performance for core virtualization processes <ul style="list-style-type: none"> Improves application performance, live migration, provisioning, dynamic load balancing, and disaster recovery
Intel® Advanced Encryption Standard (AES) New Instructions (AES-NI)	New encryption instruction set that improves on the Advanced Encryption Standard (AES) <ul style="list-style-type: none"> Comprised of seven new instructions, Intel® AES-NI gives your IT environment faster, more affordable data protection and greater security; making pervasive encryption feasible in areas where previously it was not.

Intel Atom® C3000 Processor SKU List

Processor Number ^A	CPU Cores	Speed	Power	High-Speed Input/Output (HSIO)	Memory Support (Up to 256 GB DDR4)	Integrated Intel® Ethernet	Integrated Intel® QuickAssist Technology
Server and Cloud Storage SKUs							
Intel Atom® C3955 Processor	16	2.1 GHz	32W	20	2400 MHz, 2 CH	4 x 10 GbE	N/A
Intel Atom® C3950 Processor	16	1.7 GHz	24W	20	2400 MHz, 2 CH	2 x 10 GbE	N/A
Intel Atom® C3850 Processor	12	2.1 GHz	25W	20	2400 MHz, 2 CH	2 x 10 GbE	N/A
Intel Atom® C3830 Processor	12	1.9 GHz	21.5W	12	2133 MHz, 2 CH	2 x 10 GbE	N/A
Intel Atom® C3750 Processor	8	2.2 GHz	21W	12	2400 MHz, 2 CH	2 x 10 GbE	N/A
Network and Enterprise Storage SKUs							
Intel Atom® C3958 Processor	16	2.0 GHz	31W	20	2400 MHz, 2 CH	4 x 10 GbE	Up to 20 Gbps
Intel Atom® C3858 Processor	12	2.0 GHz	25W	20	2400 MHz, 2 CH	4 x 10 GbE	Up to 20 Gbps
Intel Atom® C3758 Processor	8	2.2 GHz	25W	20	2400 MHz, 2 CH	4 x 10 GbE	Up to 10 Gbps
Intel Atom® C3558 Processor	4	2.2 GHz	16W	12	2133 MHz, 2 CH	2 x 10 GbE and 2 x 2.5 GbE	Up to 5 Gbps
Intel Atom® C3538 Processor	4	2.1 GHz	15W	12	2133 MHz, 2 CH	2 x 10 GbE and 2 x 2.5 GbE	Up to 5 Gbps, Compression Only
Intel Atom® C3338 Processor	2	1.5 GHz	8.5W	Up to 10	1866 MHz, 1 CH	4 x 2.5 GbE	N/A
Internet of Things (IoT) SKUs and Extended Ambient Operation Temperature (eTEMP) from -40°C to +85°C SKUs							
Intel Atom® C3808 Processor	12	2.0 GHz	24W	Up to 20	2133 MHz, 2 CH	4 x 10 GbE	Up to 20 Gbps
Intel Atom® C3708 Processor	8	1.7 GHz	17W	20	2133 MHz, 2 CH	4 x 10 GbE	Up to 10 Gbps
Intel Atom® C3508 Processor	4	1.6 GHz	11.5W	8	1866 MHz, 2 CH	4 x 2.5 GbE	Up to 5 Gbps
Intel Atom® C3308 Processor	2	1.6 GHz	9.5W	6	1866 MHz, 1 CH	4 x 2.5 GbE	Up to 5 Gbps

Processor information is subject to change without notice. For current product information, please visit ark.intel.com. Learn more about Intel Atom processors for the data center at intel.com/atomc.

Intel Atom® C3000 Processor - Software Support

Software Support	
Type	Software Title
Linux*	Red Hat Enterprise Linux* 7.3, 7.4
	SUSE* Linux Enterprise Server 12 SP3
	Ubuntu* 16.04, 16.10, 17.04 LTS
	Yocto* Linux 2.1
	CentOS* 7.3
	Wind River Linux WRL8, WRL9
Windows*	Microsoft Windows* Server 2016 (including Nano Server), Server 2012 R2
	Linux KVM (RHEL 7.3, 7.4)
VMM	VMware* ESXi 6.0
	Microsoft Windows* Hyper-V
	Xen* 4.9

Software support information is not comprehensive and is subject to change without notice. Please contact your Original Equipment Manufacturer (OEM) and Software supplier to confirm the latest support.

For more information on the Intel Atom C3000 Processor, visit intel.com/atomc

Share with Colleagues



Δ Intel processor numbers are not a measure of performance. Processor numbers differentiate features within each processor series, not across different processor sequences. See intel.com/products/processor_number for details. Intel products are not intended for use in medical, lifesaving, life sustaining, critical control, or safety systems, or in nuclear facility applications.

All dates and products specified are for planning purposes only and are subject to change without notice.

Software and workloads used in performance tests may have been optimized for performance only on Intel microprocessors. Performance tests, such as SYSmark and MobileMark, are measured using specific computer systems, components, software, operations and functions. Any change to any of those factors may cause the results to vary. You should consult other information and performance tests to assist you in fully evaluating your contemplated purchases, including the performance of that product when combined with other products. For more complete information visit www.intel.com/benchmarks.

Results have been estimated or simulated using internal Intel analysis or architecture simulation or modeling, and provided to you for informational purposes. Any differences in your system hardware, software or configuration may affect your actual performance.

Optimization Notice: Intel's compilers may or may not optimize to the same degree for non-Intel microprocessors for optimizations that are not unique to Intel microprocessors. These optimizations include SSE2, SSE3, and SSSE3 instruction sets and other optimizations. Intel does not guarantee the availability, functionality, or effectiveness of any optimization on microprocessors not manufactured by Intel. Microprocessor-dependent optimizations in this product are intended for use with Intel microprocessors. Certain optimizations not specific to Intel microarchitecture are reserved for Intel microprocessors. Please refer to the applicable product User and Reference Guides for more information regarding the specific instruction sets covered by this notice. Notice Revision #20110804

Relative performance is calculated by assigning a baseline value of 1.0 to one benchmark result, and then dividing the actual benchmark result for the baseline platform into each of the specific benchmark results of each of the other platforms, and assigning them a relative performance number that correlates with the performance improvements reported.

Intel does not control or audit third-party benchmark data or the web sites referenced in this document. You should visit the referenced web site and confirm whether referenced data are accurate.

1 Up to 4.0x storage performance improvement vs. Intel Atom® C2000 processor. Old: 1-Node, 1 x Intel Atom® Processor C2750 on Mohon Peak with 16GB total memory using ISA-L AES-CBC 256. Data source: Intel Internal Measurement, score 7.73 Cycle/Byte lower is better. New: 1-Node, 1 x Intel Atom® Processor C3958 on Ostrich Bay CRB with 32GB total memory using ISA-L AES-CBC 256. Data source: Intel Internal Measurement, score: 1.91 Cycle/Byte lower is better

2 Up to 3.4x network performance improvement vs. Intel Atom® C2000 processor. Old: Intel Atom® C2758 on SuperMicro Platform with 4GB total memory on Ubuntu 12.04 using IPsec Forwarding Performance using AES-128GCM @ 1420B. Data source: Intel Internal Measurement, Score: 7.8 higher is better. New: Intel Atom® C3958 on Harcurvar with 32GB total memory on Ubuntu*16.04.1 LTS x86_64 using IPsec Forwarding Performance using AES-128GCM @ 1420B. Data source: Intel Internal Measurement, Score: 26.58 higher is better.

3 Up to 2.3x compute performance improvement vs. Intel Atom® C2000 processor. Old: 1-Node, 1 x Intel® Atom™ Processor C2750 on Edisonville with 32 GB Total Memory on Red Hat Enterprise Linux* 7.0 kernel 3.10.0-123 using (No Software). Data Source: Request Number: 103, Benchmark: SPECint*_rate_base2006, Score: 103 Higher is better. New: 1-Node, 1 x Intel® Atom™ Processor C3955 on Harrisonville with 64GB total memory on Ubuntu 16.04 LTS Kernel 4.4.0-31-generic using SPECint*_rate_base2006. Data Source: Intel Internal Measurement, Score: 246. higher is better

4 Eight gigatransfers (GT) per second and 256b/130b encoding in PCIe 3.0 specification enables double the interconnect bandwidth over the PCIe 2.0 specification. Source: pcisig.com/news_room/November_18_2010_Press_Release/.

5 The SATA 3.x specification enables double the data rate (from 3 GB/s to 6 GB/s) of that enabled by the SATA 2.x specification. Source: sata-io.org/technology/6Gbdetails.asp.

† Memory based on 16Gb technology (including max memory configuration of 256GB) is supported but not validated on Intel platforms. Please check with your hardware vendor for specific memory support.

Information in this document is provided in connection with Intel products. No license, express or implied, by estoppel or otherwise, to any intellectual property rights is granted by this document. Except as provided in Intel's Terms and Conditions of Sale for such products, Intel assumes no liability whatsoever, and Intel disclaims any express or implied warranty, relating to sale and/or use of Intel products including liability or warranties relating to fitness for a particular purpose, merchantability, or infringement of any patent, copyright, or other intellectual property right. Intel products are not intended for use in medical, lifesaving, or life sustaining applications.

Intel technologies' features and benefits depend on system configuration and may require enabled hardware, software or service activation. Performance varies depending on system configuration. No computer system can be absolutely secure. Check with your system manufacturer or retailer or learn more at intel.com.

Intel may make changes to specifications and product descriptions at any time, without notice.

Copyright © 2017 Intel Corporation. All rights reserved. Intel, the Intel logo, the Intel Inside logo, Intel Xeon, and Intel Atom are trademarks of Intel Corporation or its subsidiaries in the U.S. and/or other countries.

*Other names and brands may be claimed as the property of others.

Printed in USA 0817/JN/HBD/PDF Please Recycle